

KRACHT



Screw-Type Flow Meter

SVC

Description

Screw-type flow meters belong to the group of positive displacement flow meters. Two measuring spindles (pos. 2) with a screw-shaped profile engage with each other. They are low-friction mounted using roller contact bearings (pos. 3) and enclosed by a housing (pos. 1). The liquid flow causes the spindles to rotate and passes through the device in an axial direction. In so doing, self-contained part volumes are formed which are continuously filled and emptied. This principle of measurement causes no pressure and/or flow pulsations.

A sensing wheel attached to the measuring spindle (pos. 4) is scanned by two non-contact sensors. Using two sensors, a bidirectional flow with detection of flow-direction is possible. The inflow and outflow occurs almost without deflection. Consequently, the device exhibits a relatively low drop in pressure. Measuring this way does not require the flow to be calmed at the inlet and outlet. All moving parts are lubricated by the measurement medium.

Construction

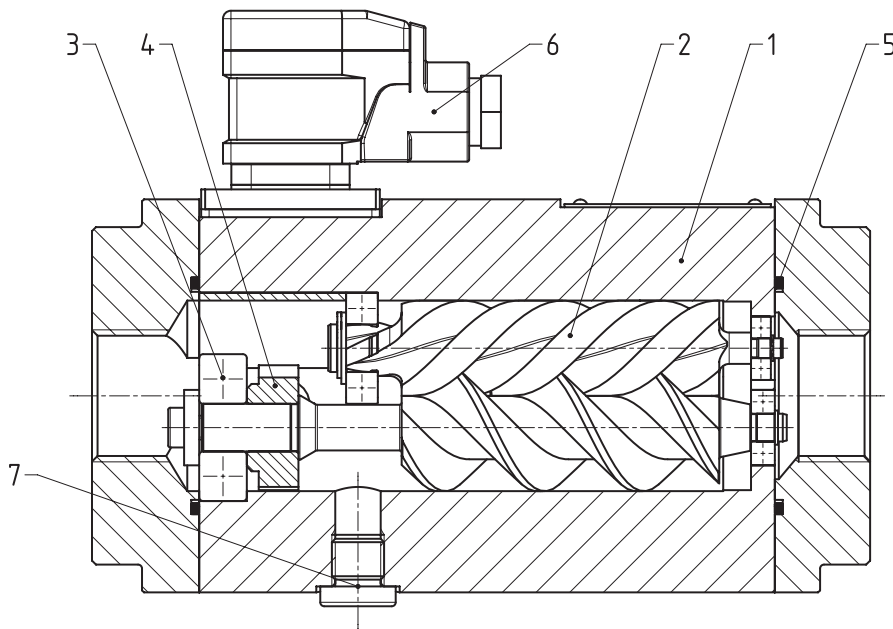

- | | |
|-------------------------------------|--|
| 1 Housing | 5 Seal (O-ring) |
| 2 Measuring system (screw spindles) | 6 Connection |
| 3 Bearing (roller contact bearing) | 7 Measuring connection
(pressure, temperature etc.) |
| 4 Sensing wheel and sensors | |

Product Characteristics

- Very low pressure drop
- High-response measurement
- Measurement with changing flow direction
- pulsation free measurement principle
- High working pressure
- Very low noise emission
- Measurement independent of viscosity within the specified ranges
- High-precision measurement with outstanding reproducibility
- Temperature-independent output signals over a wide temperature range
- High degree of accuracy, even with low flow rates at the bottom end of the measuring range
- High working reliability of the electronics
- Easy to use terminal of the preamplifier
- Working indication of the electronic
- Sensor system and preamplifier in EMC-compatible design
- Explosion-proof version available (ATEX)

Accuracy Characteristics

- The accuracy figures quoted by KRACHT refer to the impulse volume [cm³/Imp], that is to say the percentage deviation applies to the current value in each case.
- The linearity error over the entire measuring range is $\pm 0.1\%$.
- Reproducibility of a measured value is $< 0.1\%$.
- Accuracy checking forms part of quality inspection in every case.
- On request the result of the test will be documented in the form of an accuracy characteristic curve; an example relating to a SVC 10 A1 is given below.
- The accuracy values quoted by Kracht are confirmed by the DKD (German Calibration Service).

Accuracy

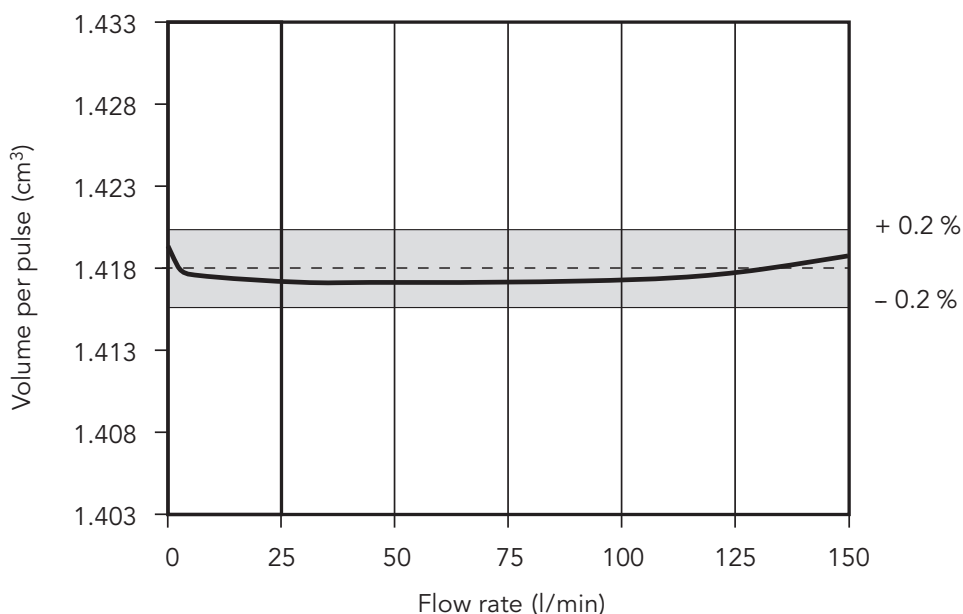

Linearity

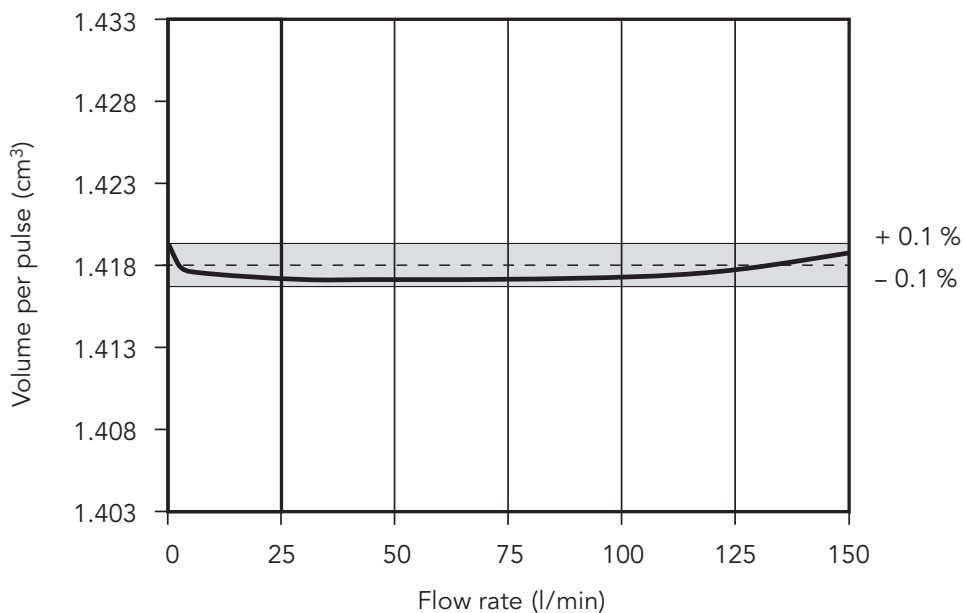

Materials

Housing and flanges	EN-GJS-400-15 (GGG-40)
Measuring spindles	Heat-treated steel
Roller contact bearing	Heat-treated steel
O-ring	FKM, EPDM, FEP (other sealing materials on request)

Characteristics

Mounting position	optional		
Flow direction	optional		
Connection type	Pipe thread, SAE-flange, DIN-flange		
Working pressure	SVC 4, SVC 10 SVC 40 SVC 100 SVC 250	p_{max} p_{max} p_{max} p_{max}	= 400 bar = 250 bar ($p_{max} = 40$ bar at sealing material L) = 140 bar = 40 bar
Max. pressure drop	(short-time) (permanent) SVC 100 (\otimes -version)	Δp_{max} Δp_{max} Δp_{max}	= 25 bar = 7 bar (at 50 % of the max. flow rate) = 10 bar
Viscosity	1 ... 1,000,000 mm ² /s (depending on the flow)		
Sound power level	SVC 10 SVC 40 (at 100% of the max. flow rate)	L_{WA} L_{WA}	= 46 dB (A) = 52 dB (A)

Permitted Temperature Ranges

Sealing Materials	FKM	EPDM	FEP	FKM low temperature
Ambient temperature	-15 °C ... 80 °C	-30 °C ... 80 °C	-30 °C ... 80 °C	-40 °C ... 80 °C
Media temperatures:				
Standard version	-15 °C ... 120 °C	-30 °C ... 120 °C	-30 °C ... 120 °C	-40 °C ... 120 °C
High temperature version	-15 °C ... 150 °C	n. a.	-30 °C ... 150 °C	-40 °C ... 150 °C
High temperature PLUS version	n. a.	n. a.	-30 °C ... 220 °C	n. a.
\otimes -version	-15 °C ... 80 °C	-30 °C ... 80 °C	-30 °C ... 80 °C	n. a.

Working Characteristics

Nominal size	Impulse volume cm ³ /Imp	Resolution (K-factor) Imp/l	Resolution (K-factor) 4-fold* Imp/l	Pulse rate at Q_{nenn} Hz	Accuracy (from measuring value) at ≥ 20 mm ² /s %	Starting point Mounting position		Measuring range l/min
						horizontal l/min	vertical l/min	
4	0.255	3921.6	15686.3	2614	± 0.3	0.03	0.01	0.4... 60
10	1.418	705.2	2820.9	1175	± 0.2	0.05	0.02	1.0 ... 150
40	5.130	194.9	779.7	1300	± 0.2	0.10	0.02	4.0 ... 600
100	9.82	101.8	407.3	1697	± 0.2	0.15	0.03	10.0 ... 1500 10.0 ... 1000 (\otimes -version)
250	18.25	54.8	219.2	2283	± 0.2	0.90	0.06	25.0 ... 3750

Note: The ATEX characteristics SVC 10 and SVC 40 correspond to the standard characteristics.

* Resolution with 4-fold evaluation of both measuring canals

Type Key

Ordering example

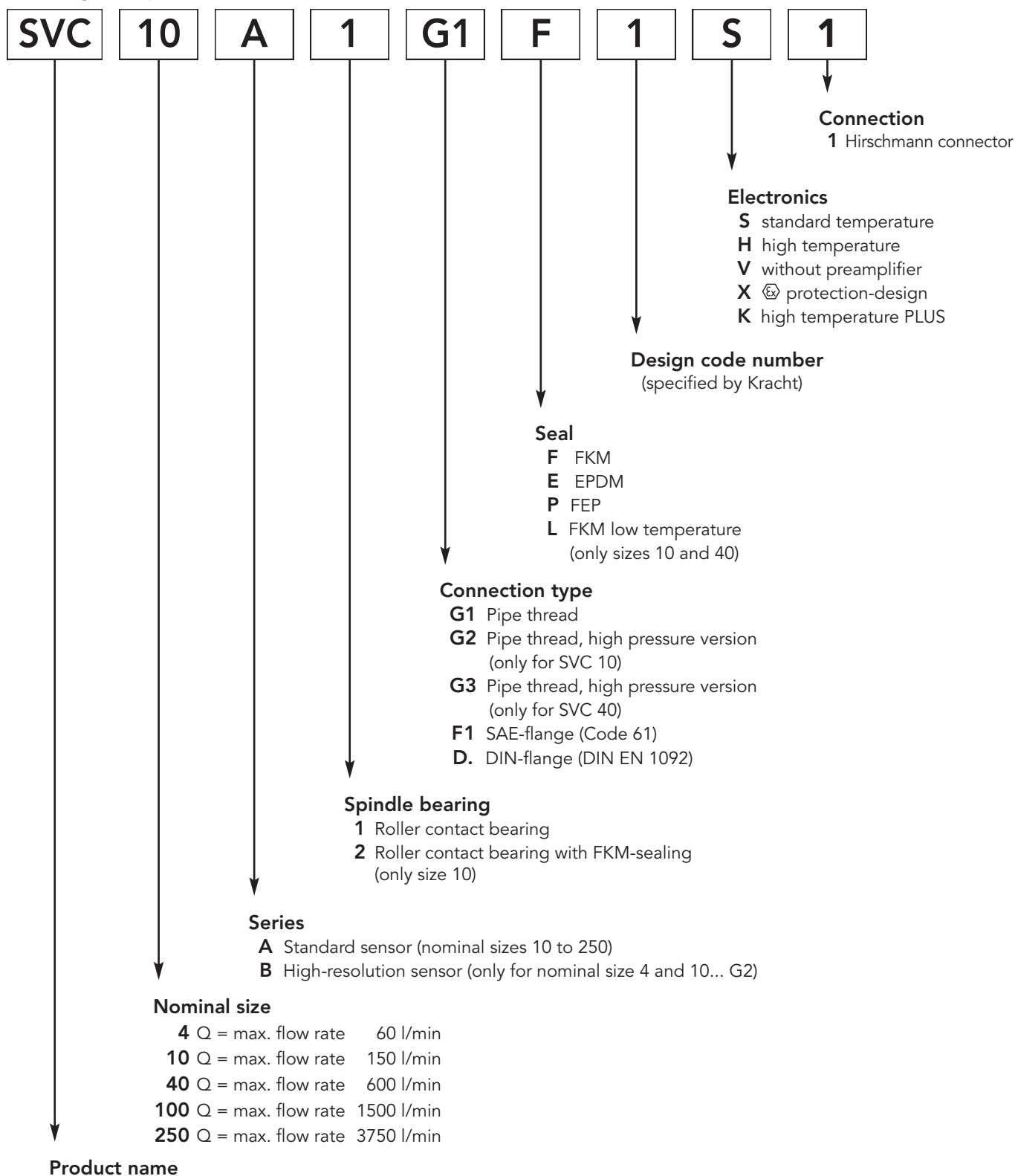

Electrical Connection

Electronic: S and H

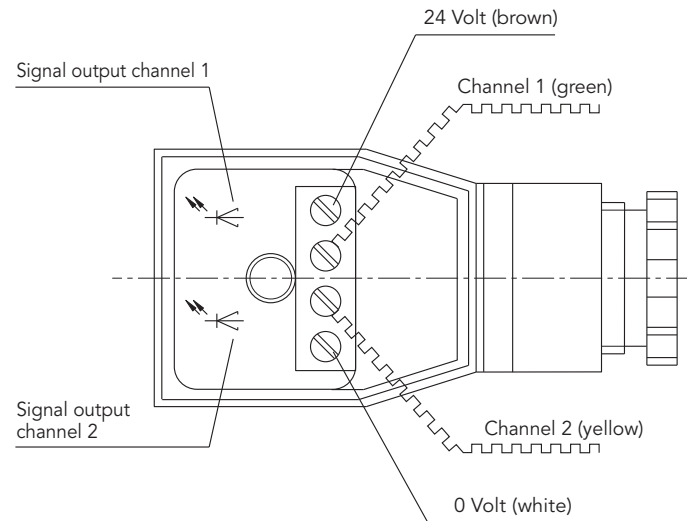

Electrical Characteristics

Number of measuring channels	2	Pulse offset between two channels*	$90^\circ \pm 30^\circ$
Operating voltage	$U_{op} = 12 \dots 30$ VDC polarized	Power requirement	$P_{b\ max} = 0.9$ W
Pulse amplitude	$U_A \ 0.8 \ U_B$	Output power/channel	$P_{a\ max} = 0.3$ W short-circuit-proof
Pulse shape with symm. output signal	square wave pulse duty factor/channel $1:1 \pm 15\%$	Degree of protection	IP 65 DIN 40050
Signal output	PNP (NPN on request)		

Signal Characteristics

Channel I

- A rising edge
- B one pulse (corr. to flow rate of geom. tooth volume V_{gz})
- C falling edge
- D ON phase
- E OFF phase
- F pulse duty factor $1:1 \pm 15\%$

Channel II*

- G channel offset
- H flow direction 1
- K reversal of flow direction
- J flow direction 2

* only at two channel version

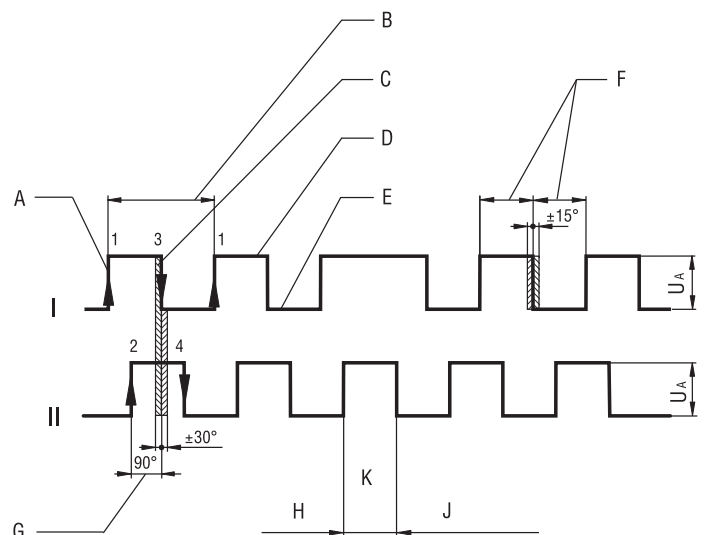

Explosion-Proof Design (ATEX)

Function

- All screw-type flow meters are available in explosion-proof design according to ATEX.
- The explosion-proof design consists of the screw-type flow meter (intrinsically safe electrical apparatus) and the switching amplifier K 130 (associated electrical apparatus). The type of protection „intrinsic safety” applies to this construction.
- The screw-type flow meter is installed in the potentially explosive atmosphere.
- The mounting of the amplifier K 130 is carried out in the safe area.
- Screw-type flow meter and switching amplifier are electrically connected to each other. The switching amplifier evaluates the sensor signals and converts them to square-wave signals.
- Without switching amplifier, the screw-type flow meter must not be operated in the potentially explosive atmosphere.
- Cable lengths of up to 400 m are possible between screw-type flow meter and switching amplifier.
- LED's for monitoring line breaks / short circuits, channel switching state and power supply are located on the switching amplifier.

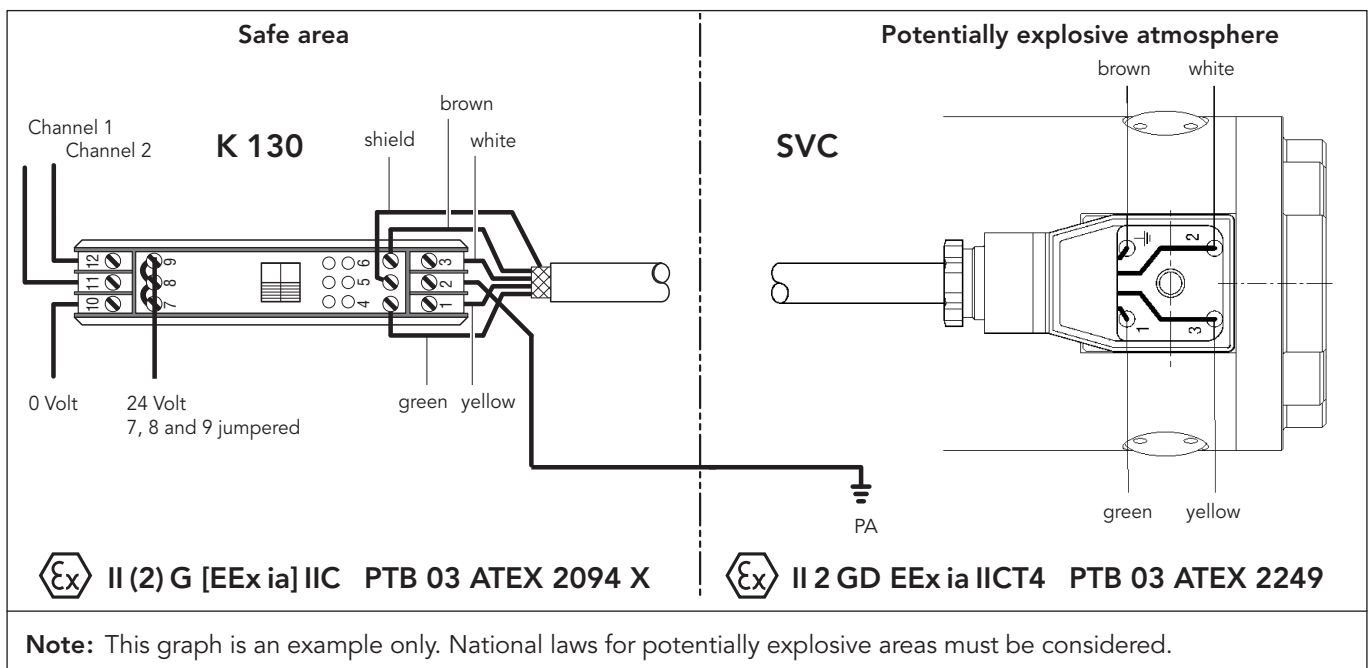

Technical Data of Switching Amplifier K-130/3-E-10

Power supply

Supply voltage cl. 7 (L+), cl. 10 (L-)
Ripple content white Wss

DC 24 Volt \pm 20 %
< 10 %

Outputs (non-intrinsically safe)

Characteristics cl. 9, 12, 8, 11

Electronics outputs
Short-circuit current
Signal level 1-signal
Signal level 0-signal

electrically isolated via optoelectronic coupler
approx. 25 mA
0.8 x supply voltage with $R_L > 2\text{ k ohm}$
inhibited output, residual current < 10 uA

Ambience conditions

Minimum limiting temperature
Maximum limiting temperature

248 K (- 25 °C)
333 K (+ 60 °C)

Mechanics

Dimensions
Connection possibility
Weight

107.5 x 92 x 22 mm
can be snapped on a 35 mm mounting channel DIN 46277
approx. 150 g

Pressure Drop Parameter: Viscosity (mm²/s)

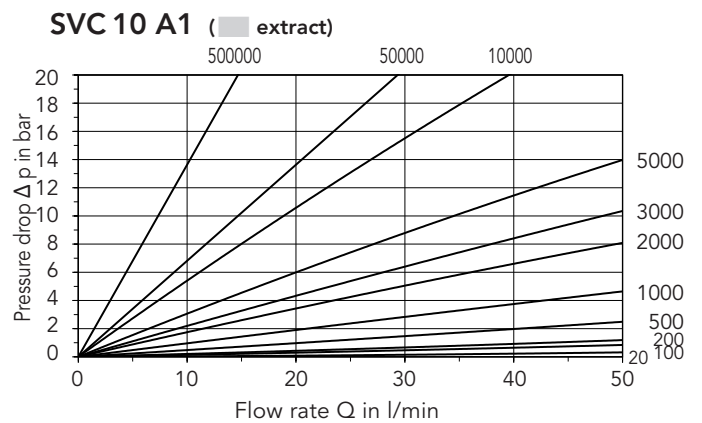
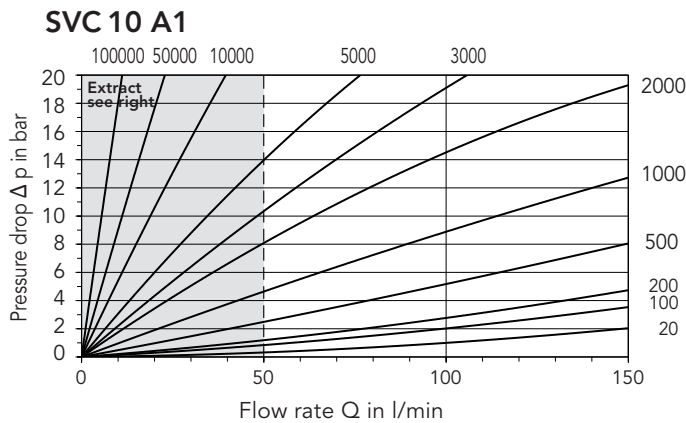
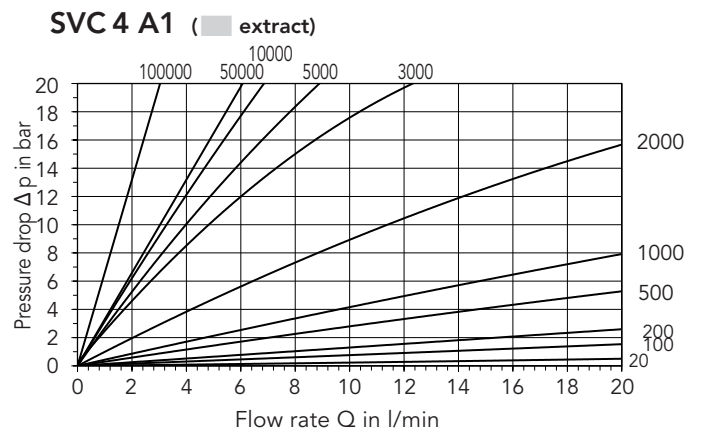
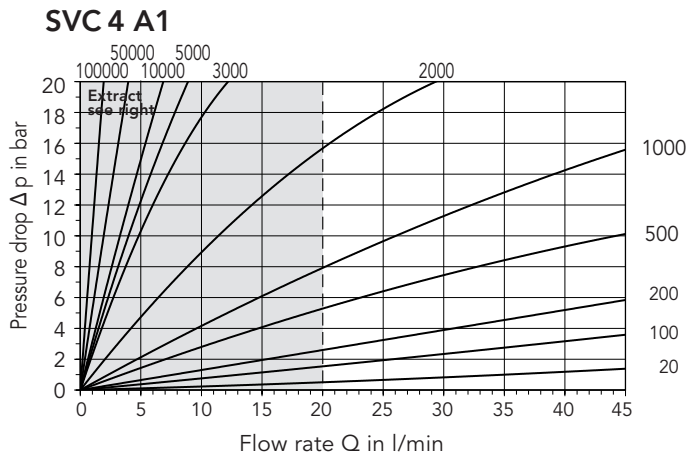
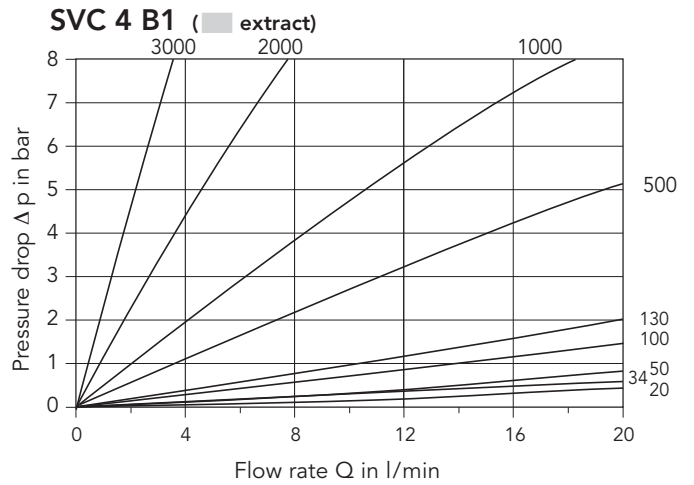
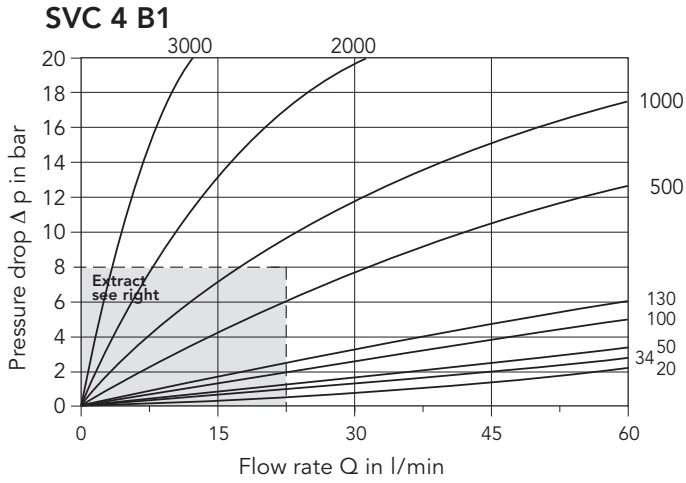

Pressure Drop Parameter: Viscosity (mm²/s)

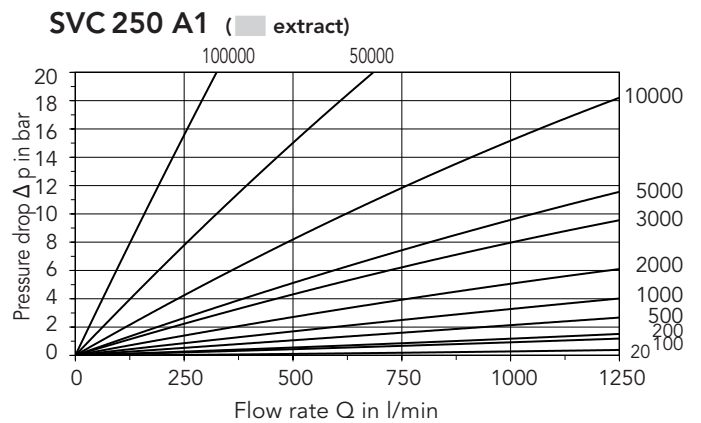
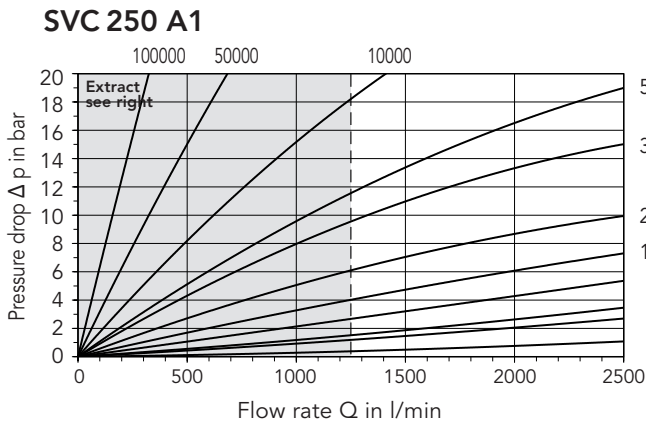
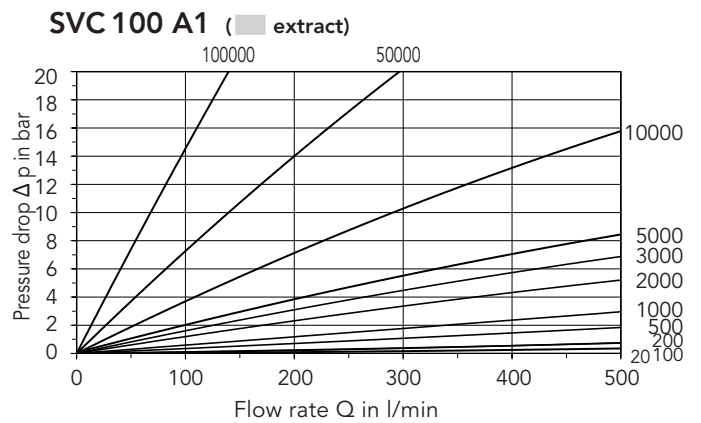
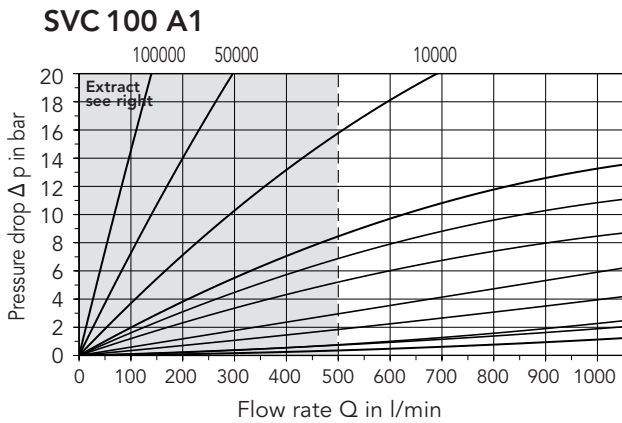
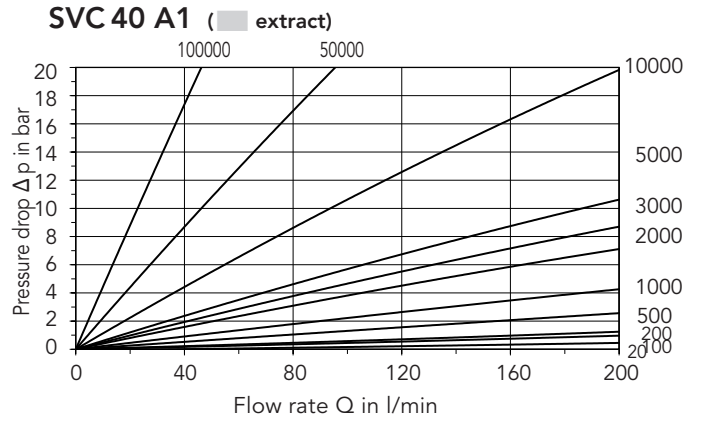
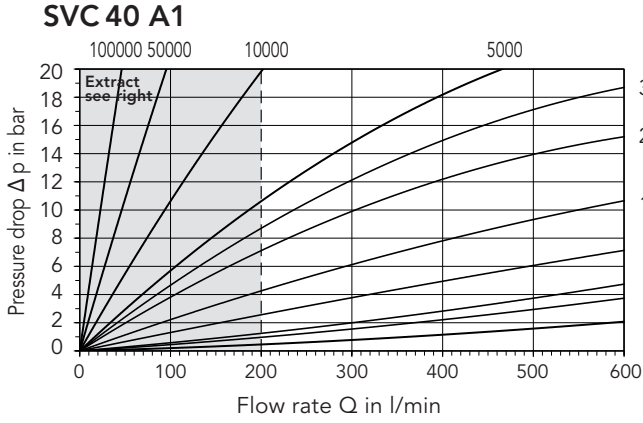

Dimensions SVC 4 (in mm)

Connection – Pipe thread (SVC 4 B1 G1)

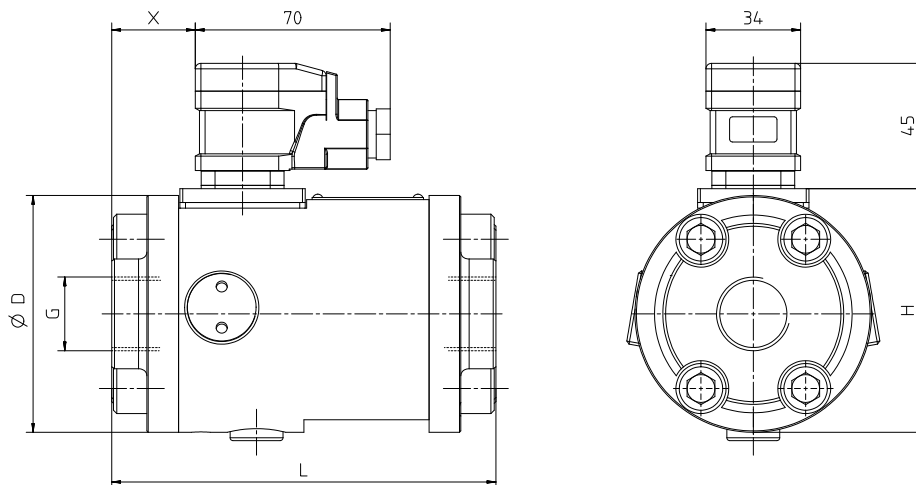

Connection – SAE-flange (Code 61) (SVC 4 B1 F1)

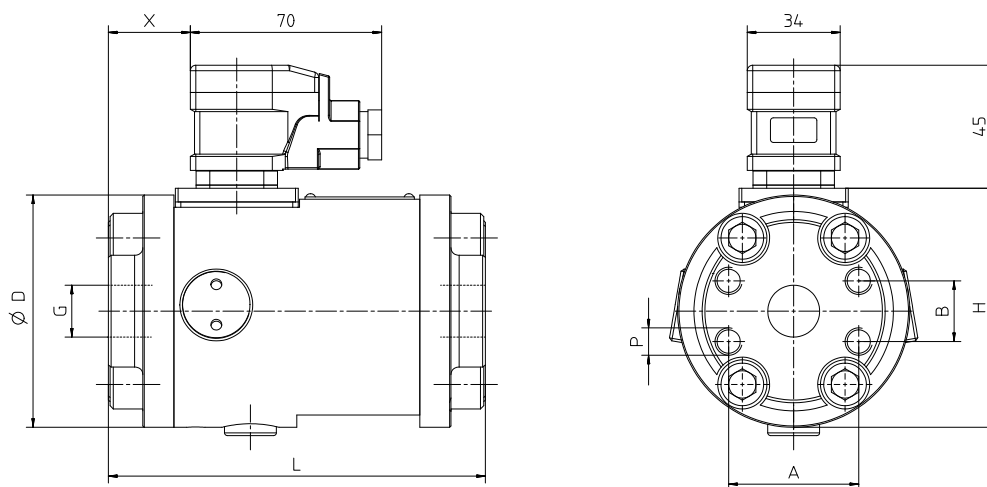

Nominal size	A	B	D	L	K	H	G	P	X	Weight kg
4 B1 G1	–	–	85	138	–	87.5*	G ¾	–	30	4.7
4 B1 F1	47.6	22.2	85	138	–	87.5*	SAE ¾	M10 – 22 deep	30	4.7

* plus 3 mm for electronic type "H"

Dimensions SVC 10 (in mm)

Connection – Pipe thread (SVC 10 A1 G1)

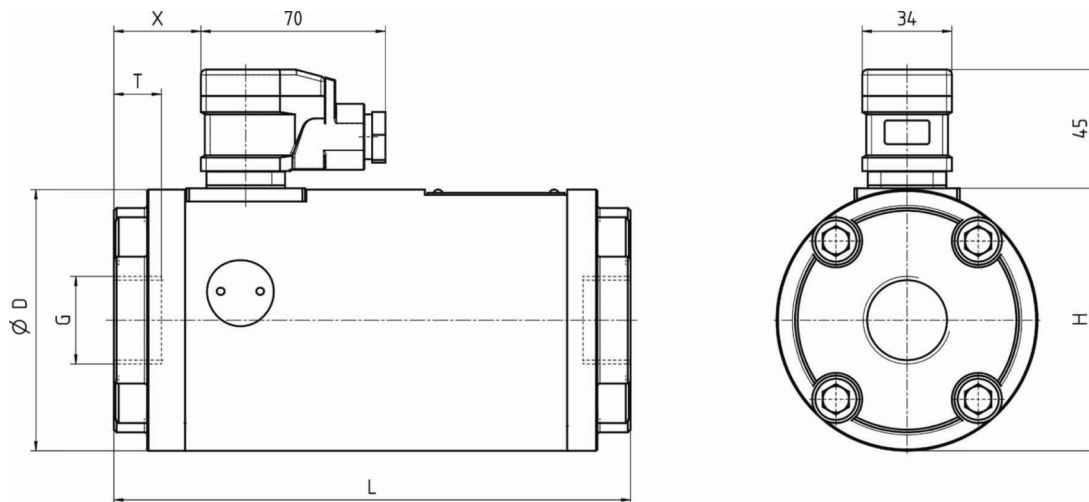

Connection – SAE-flange (Code 61) (SVC 10 A1 F1)

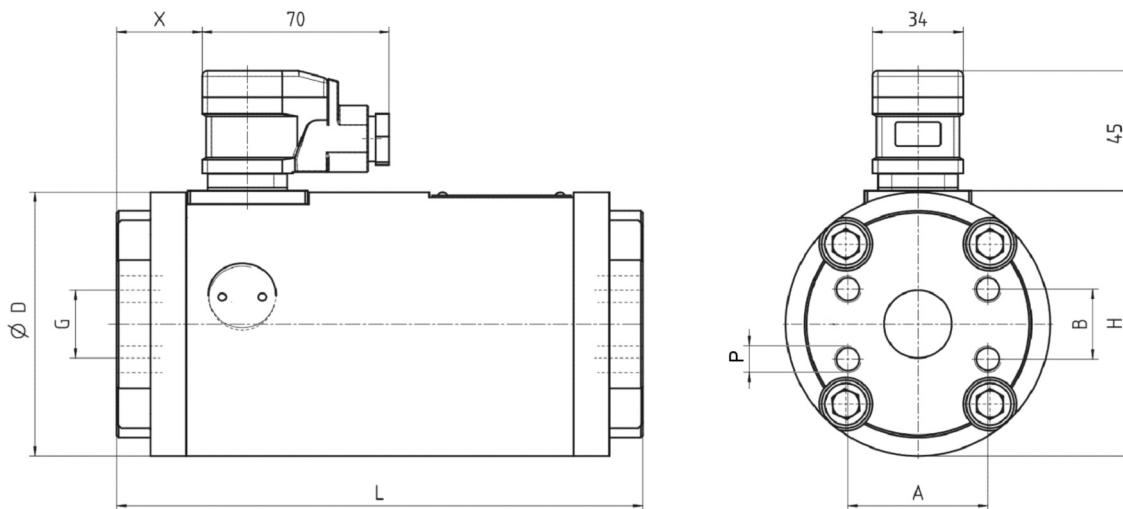

Connection – DIN-flange

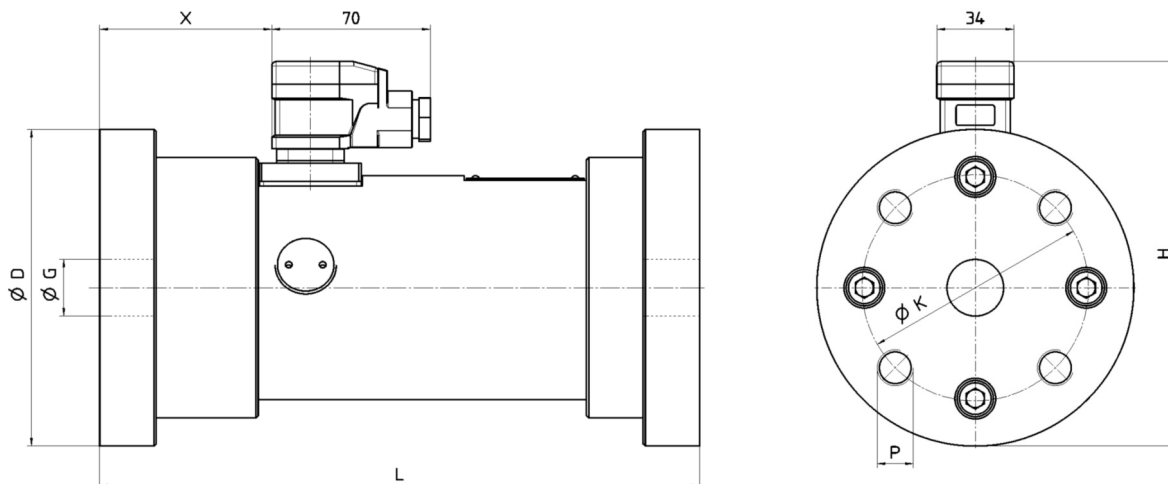

Dimensions SVC 10 (in mm)

Nominal size	A	B	D	L	K	H	G	P	T	X	Weight kg
10 A1 G1	–	–	99	196	–	101.5*	G 1	–	19	33	9.6
10 A1 F1	52.4	26.2	99	197	–	101.5*	SAE 1	M10 – 17 deep	–	32	9.6
10 A1 D1	–	–	140	265	100	167*	32	M16 – 25 deep	–	76	17.2
10 A1 D2	–	–	140	265	100	167*	25	M16 – 25 deep	–	76	17.3
10 A1 D3	–	–	150	275	105	172*	25	M20 – 30 deep	–	81	19.15

* plus 3 mm for electronic type "H"

Available DIN-flanges – type SVC 10

	Diameter Nominal DN (mm)	Pressure drop PN (bar)
D1	32	40
D2	25	160
D3	25	250

Dimensions SVC 40 (in mm)

Connection – Pipe thread (SVC 40 A1 G1)

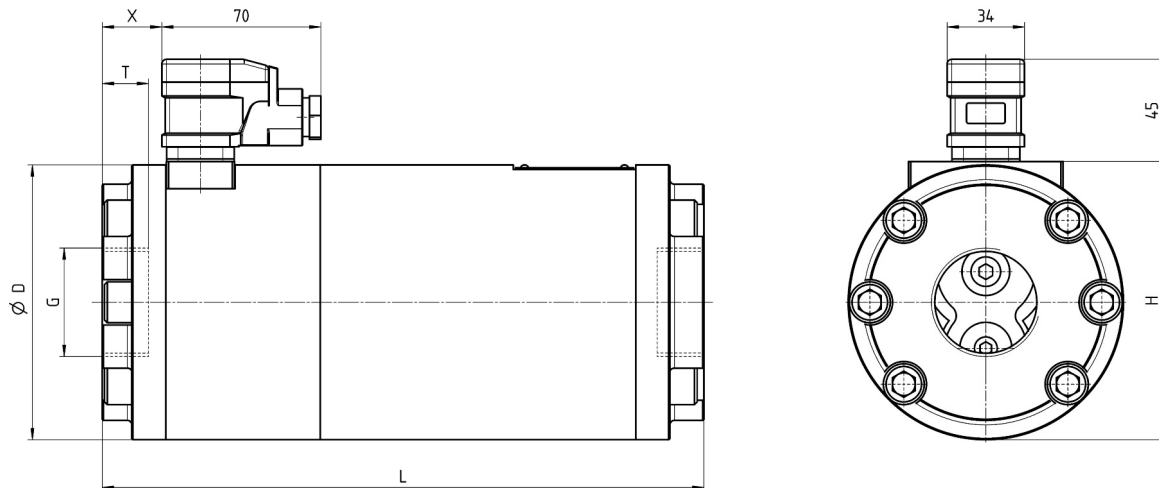

Connection – SAE-flange (Code 61) (SVC 40 A1 F1)

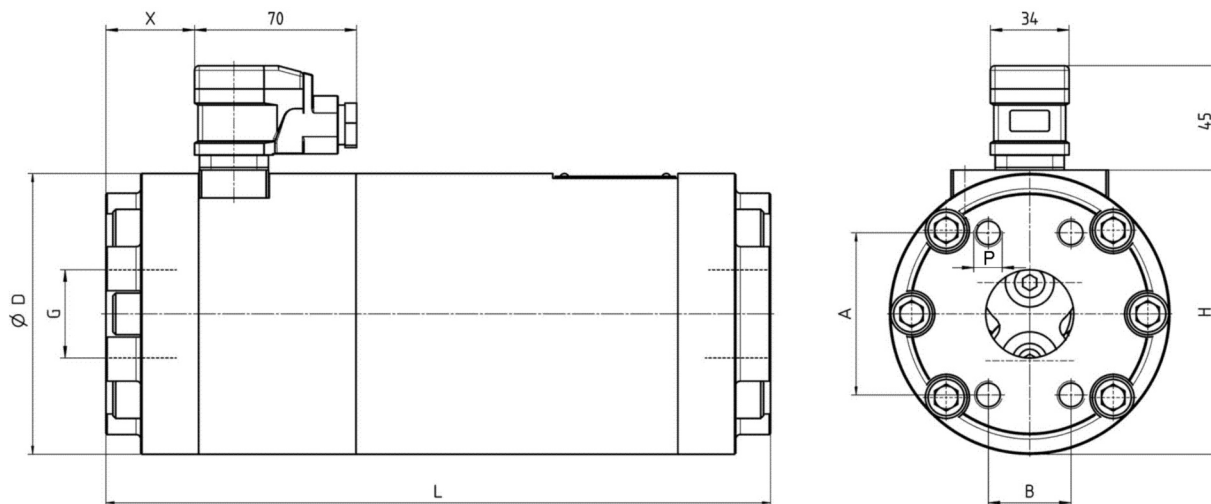

Connection – DIN-flange

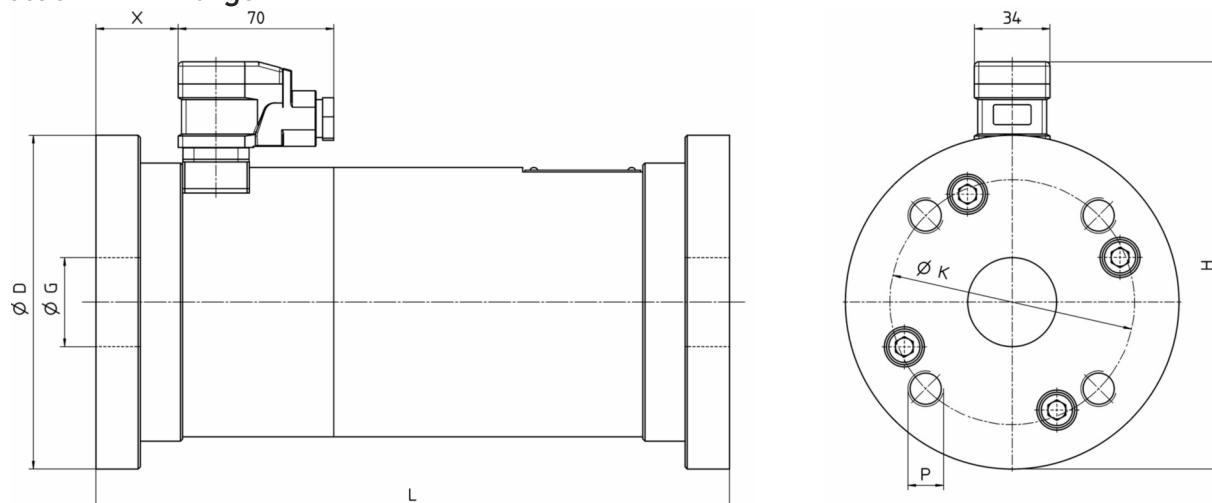

Dimensions SVC 40 (in mm)

Nominal size	A	B	D	L	K	H	G	P	T	X	Weight kg
40 A1 G1	–	–	121	265	–	123.5*	G1½	–	23	26	18.0
40 A1 F1	69.9	35.7	–	287	–	123.5*	SAE1½	M12 – 27 deep	–	38	18.9
40 A1 D1	–	–	150	285	110	183*	40	M16 – 20 deep	–	37	24.65
40 A1 D2	–	–	170	295	125	193*	40	M20 – 25 deep	–	42	27.5

* plus 11 mm for electronic type "H"

Available DIN-flanges – type SVC 40

	Diameter Nominal DN (mm)	Pressure drop PN (bar)
D1	40	40
D2	40	160

Dimensions SVC 100 (in mm)

Connection – Pipe thread (SVC 100 A1 G1)

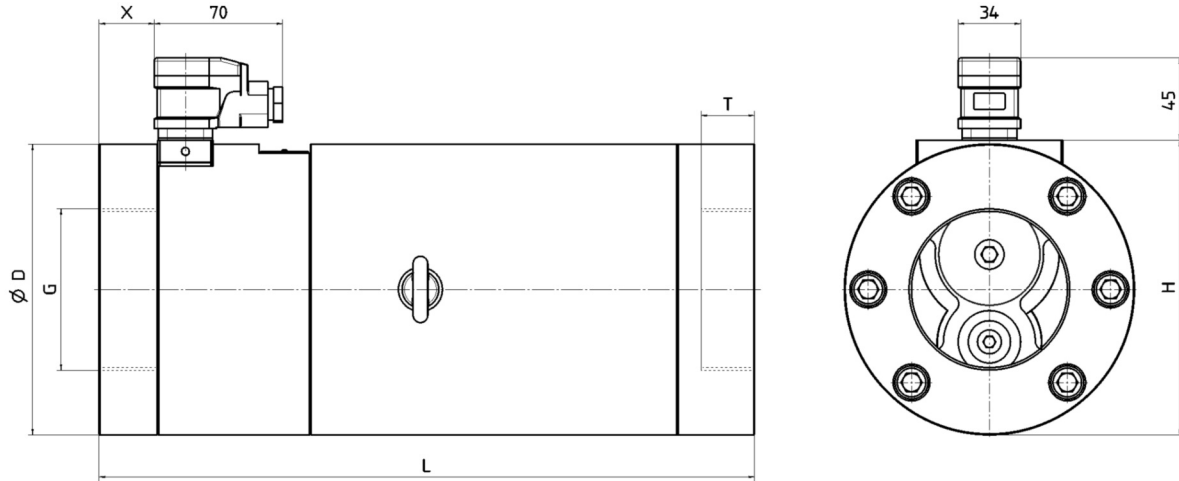

Connection – SAE-flange (SVC 100 A1 F1)

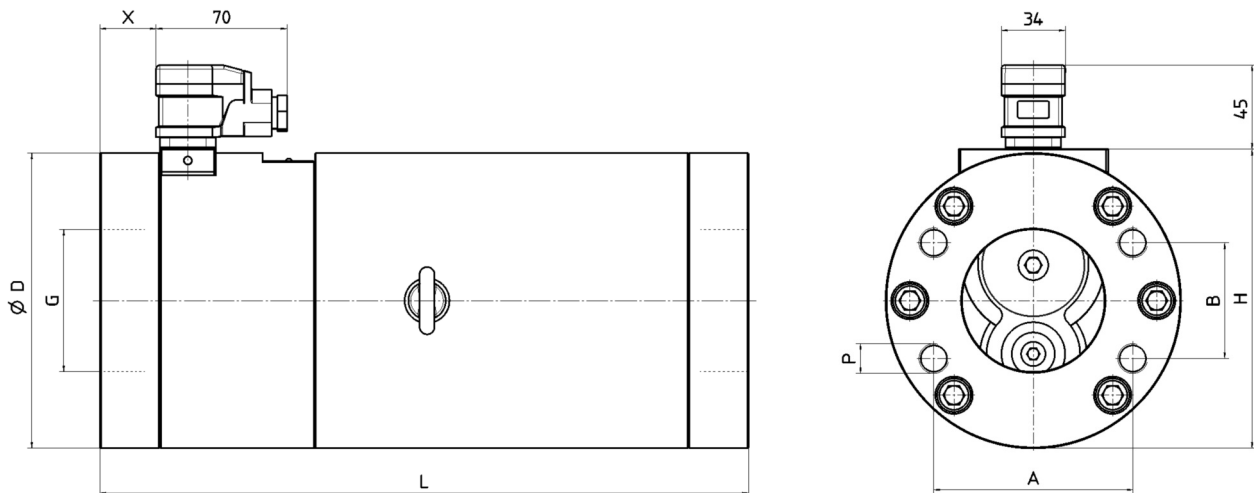

Connection – DIN-flange

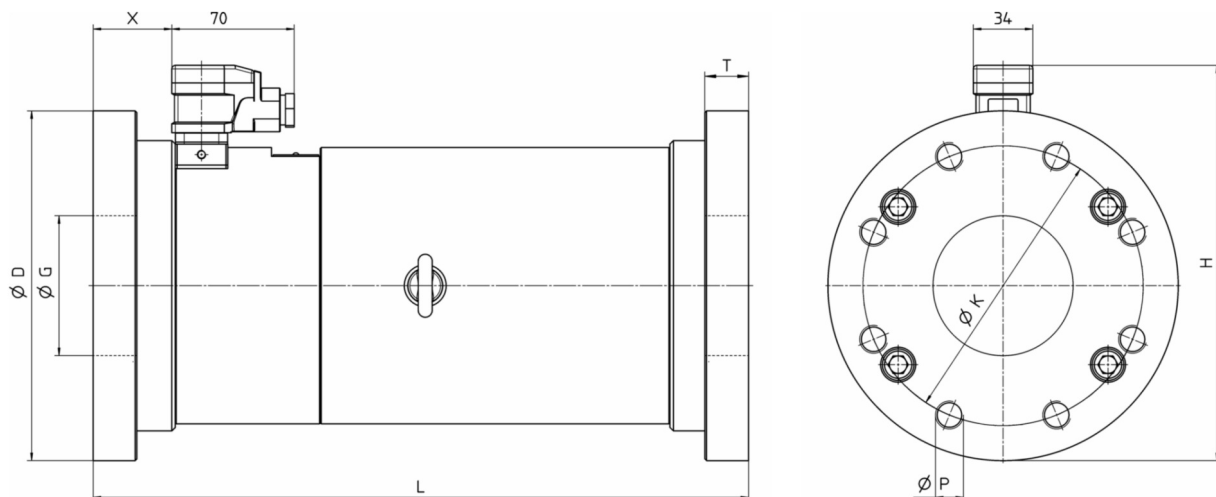

Dimensions SVC 100 (in mm)

Nominal size	A	B	D	L	K	H	G	P	T	X	Weight kg
100 A1 G1	–	–	158	357	–	160*	G 3	–	32	30	39.1
100 A1 F1	106.4	61.9	158	347	–	160*	SAE 3	M16 – 32 deep	–	32	38.7
100 A1 D1	–	–	200	365	160	226*	80	M16 – 25 deep	–	45	46.2

* plus 11 mm for electronic type "H"

Available DIN-flanges – type SVC 100

	Diameter Nominal DN (mm)	Pressure drop PN (bar)
D1	80	40

Dimensions SVC 250 (in mm)

Connection – SAE-flange (SVC 250 A1 F1)

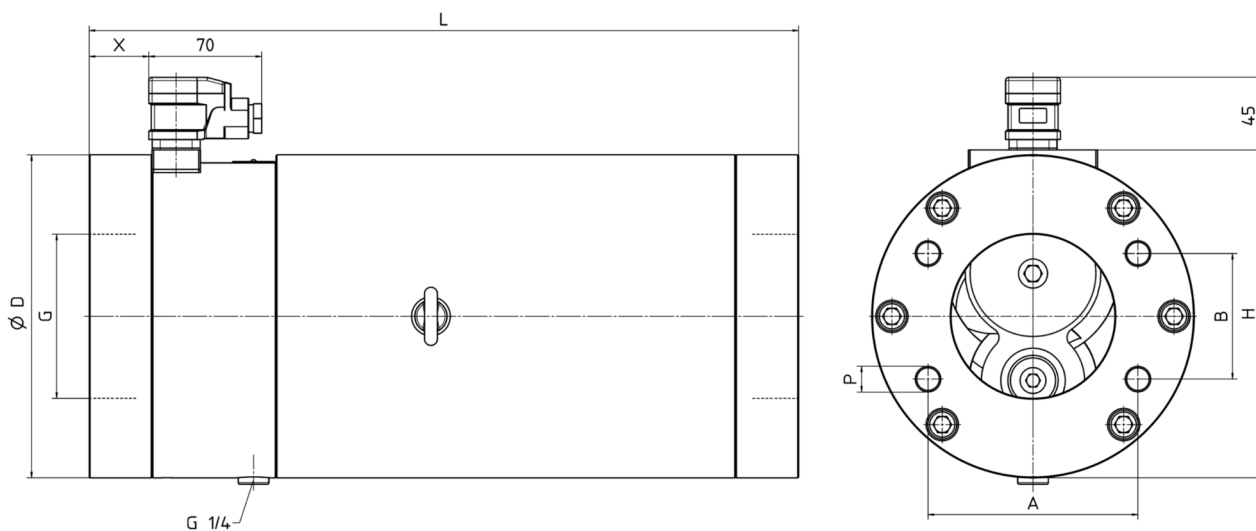

Nominal size	A	B	D	L	K	H	G	P	T	X	Weight kg
250 A1 F1	130.2	77.8	200	440	–	203*	SAE 4	M16 – 30 deep	–	37	76

* plus 11 mm for electronic type "H"

Product Portfolio

Gear Pumps

Gear pumps for lubricating oil supply equipment, low pressure filling and feed systems, dosing and mixing systems.

Hydraulics

Single and multistage high pressure gear pumps and hydraulic motors for construction machinery, vehicle-mounted machines.

Flow Measurement

Gear, turbine and screw type flow meters and electronics for volume and flow metering technology in hydraulics, processing and laquering technology.

Valves

Cetop directional control and proportional valves, pressure, quantity and stop valves for pipe and slab construction.



SVC/GB/03.19

KRACHT

KRACHT GmbH · Gewerbestraße 20 · 58791 Werdohl, Germany · Phone +49 23 92.935-0 · Fax +49 23 92.935 209

Email info@kracht.eu · Web www.kracht.eu