

Gripper

AF19-10

Character

- Angular type by cam & roller driving unit
- Suitable to grip for small electronic workpiece
- Quick responsibility by normally open type
- Magnetic sensor is not available



Cam roller type

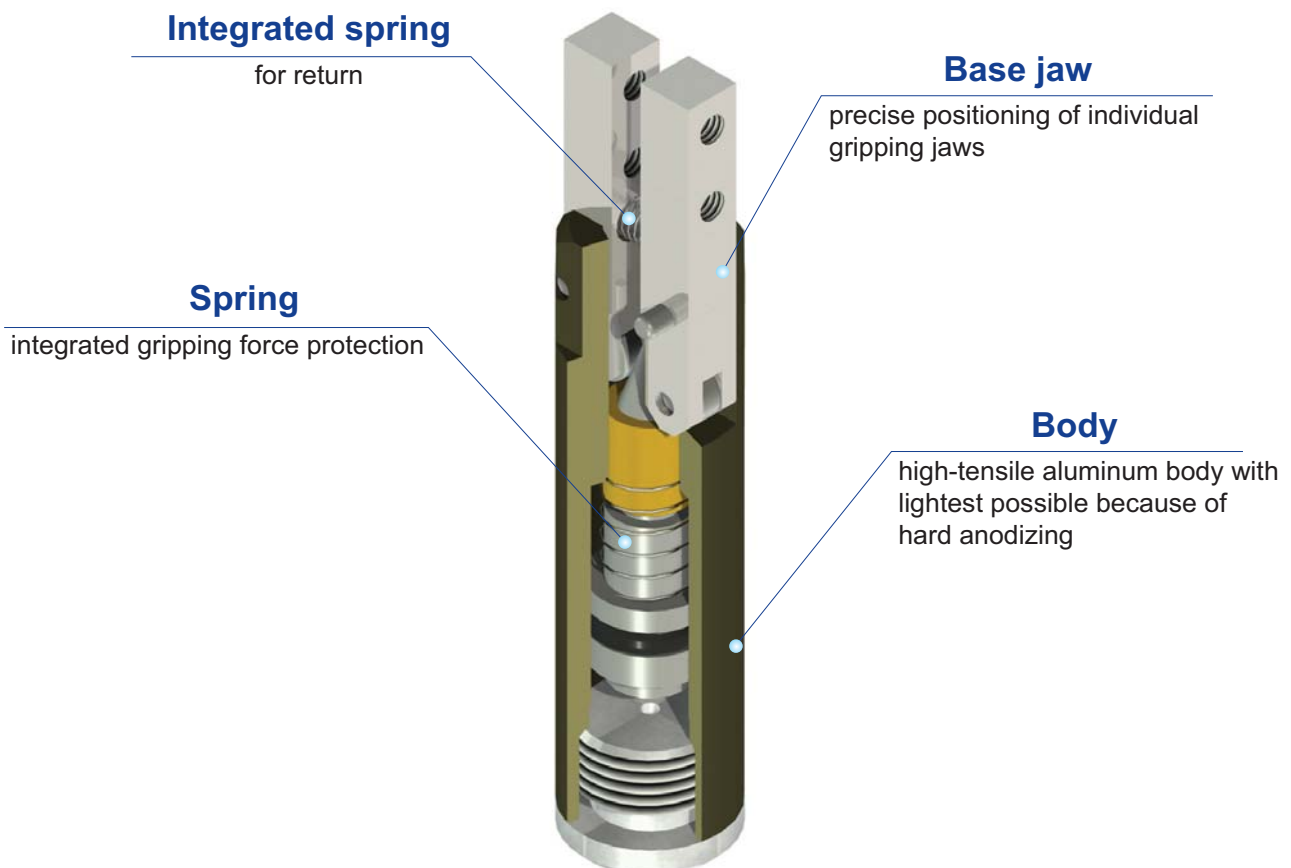

AF19

Exploded view

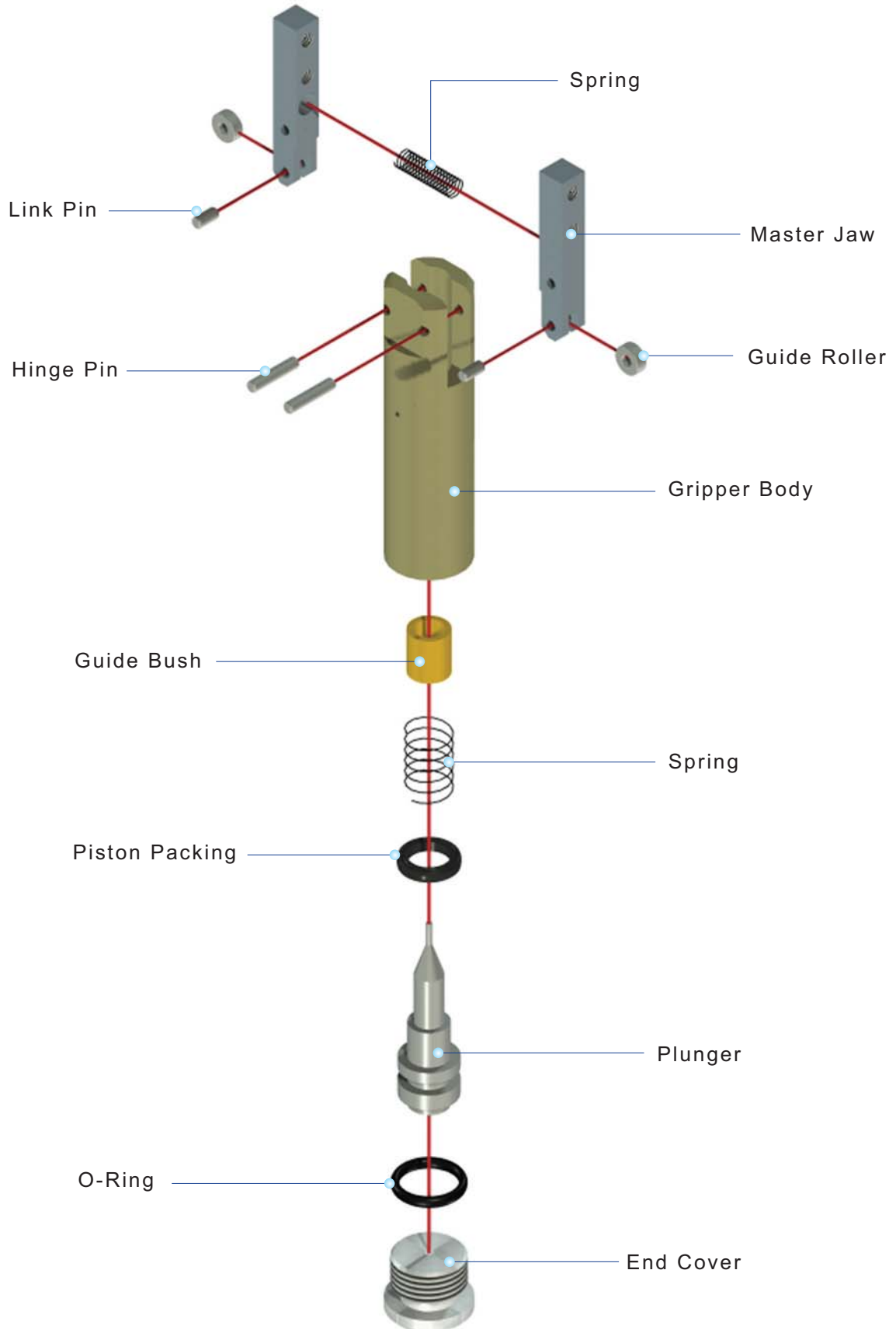

AF19

Ordering Code

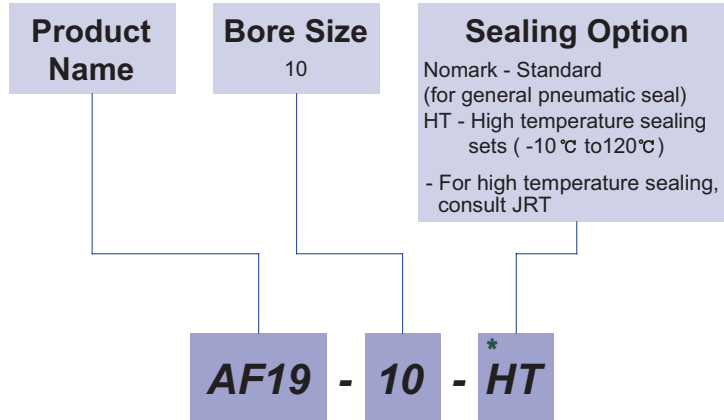

This product sensor is only back pressure sensor
 The delivery of * mark option is longer than a standard, So inquire of JRT

Specification

P=Air Pressure[bar] , L=Exertion length[mm]

Product name	AF19-10	Unit
Working angle	-7 to 14	degree
Weight	0.04	kg
Max. length of attach	30	mm
Fitting size	M5	
Gripping force:Open	—	
Gripping force:Close	5.9(P-1.5)/L	N
Max.cycle per minute	60	
Operating pressure	3 to 7	bar
Ambient temperature	-5 to 60	°C
Lubrication	Needless	

Gripping Force per exertion length

Legend : — 7[bar] — 5[bar] — 3[bar]

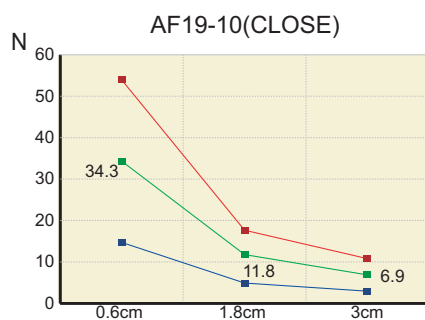

AF19

AF19-10

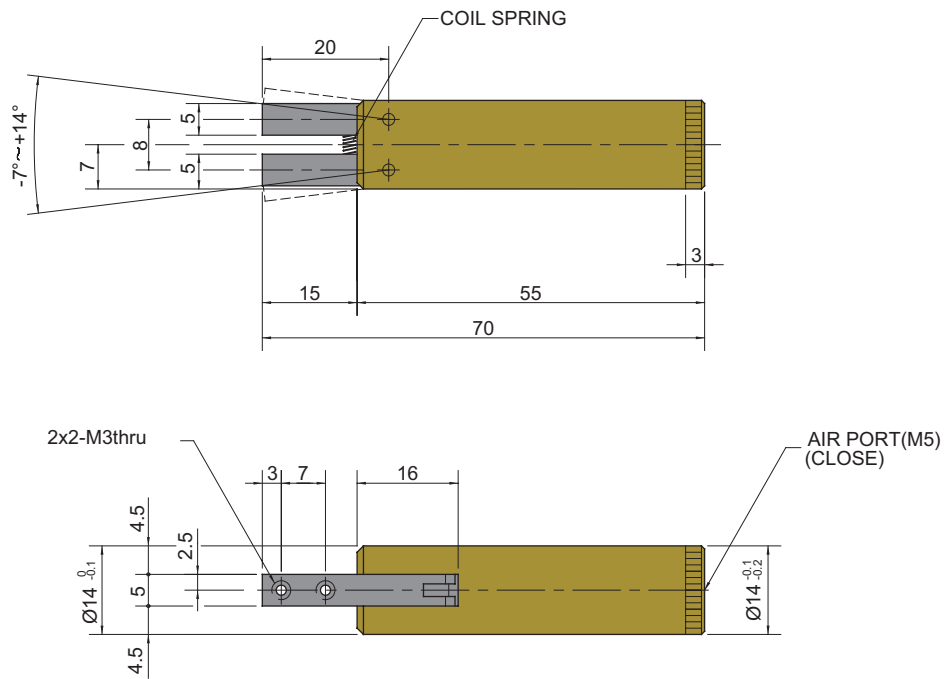

Note