

esi

GENSPEC® GS4200H

Hydrogen Pressure Transmitter

- Compatible for use within Hydrogen based environment
- Silicon-on-Sapphire sensor technology for outstanding performance
- Pressure ranges to 1,500 bar
- Specialist high strength titanium alloy sensor
- Excellent corrosion resistance
- High resistance to overpressure and pressure transients
- ATEX/IECEx option available (includes M1 for mining applications)
- DNV-GL certification available



Materials used in the manufacture of the Hydrogen range have been tested based on ISO 11114-2:2017 in accordance to the European Regulations EC 79/2009 and EU 406/2010 to determine an "embrittlement index" of the material when placed in a saturated environment over an extended period of time.

Results have provided a Pass rating to the compatibility of the specialist Titanium Alloy of the range against Hydrogen.

Specifications

The **GENSPEC GS4200H** series of Hydrogen compatible pressure transmitters, with state-of-the-art SOS sensor technology, offers a highly accurate and durable sensor capable of withstanding over pressure levels of up to twice the stated pressure range (dependent on the pressure range). Combination ATEX and DNV-GL marine certification is also available.

Typical applications include:

- Hydrogen storage
- Hydrogen production
- Marine propulsion



Dimensions (in mm)

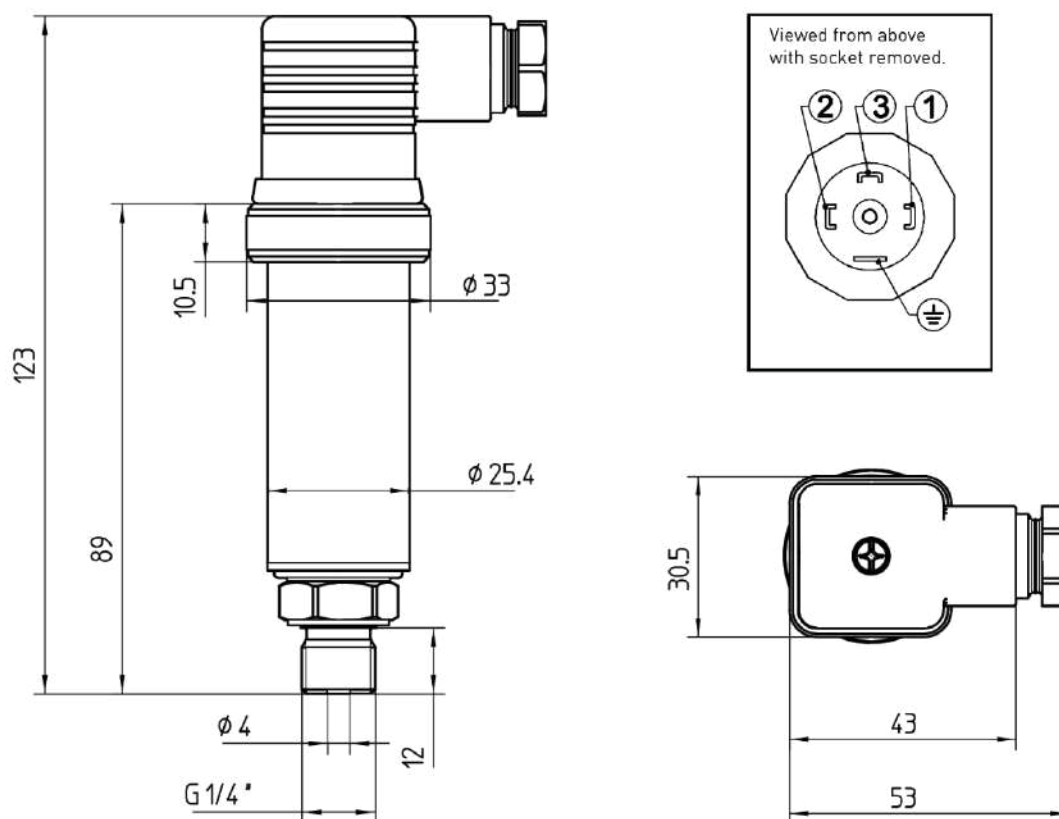

Electrical Connections

Pin No.	mA		VDC	
	2 wire	3 wire	4 wire	
1	+supply	common	-supply	
2	4-20mA	+supply	+supply	
3	N/C	+output	+output	
⊥	to case	to case	-output	

Hydrogen Compatibility and Silicon-on-Sapphire

The ESI hydrogen pressure transmitters are manufactured from a special titanium alloy for the measuring cell and a titanium block for the wetted parts. High pressure cells ranging from 1,000 bar are manufactured without seams, which aids in the avoidance of any weak points. This is especially important for the use with hydrogen due to the embrittling qualities of the media.

The combination of titanium sensing elements with SOS sensors has a long tradition at ESI, this material choice allows the construction of a long term stable sensor that has a high accuracy. The measurement ranges for this product are up to 1,500 bar, which makes this transmitter the preferred choice for use on hydrogen storage tanks and pipelines, but we also offer the same technology for low pressures and also in vacuum measurement applications.



The unique Silicon-on-Sapphire sensor technology provides outstanding performance and gives excellent stability over a wide temperature range. The advanced sensor design consists of a piezoresistive silicon strain gauge circuit, which is epitaxially grown onto the surface of a sapphire diaphragm to form a single crystalline structure. The sapphire sensor element is then molecularly bonded to a titanium alloy sub-diaphragm. This enables the sensor to endure higher over-pressures and provides superb corrosion resistance. The sensor exhibits virtually no hysteresis and excellent long-term stability. With outstanding insulation properties, the sapphire substrate allows the sensor to operate over a very wide temperature range without loss of performance.

Each Hydrogen approved unit also includes a certificate of conformity verifying Hydrogen compatibility.

Optional Approvals



Hazardous Area: ATEX and IECEx approval for explosion protection; flammable gases (zone 0), dusts (zone 20) and mining areas (group I M1).



Marine: DNV-GL marine approvals for marine use has been developed for shipping systems such as marine engines, cargo storage tanks, fuel gauging, fresh water storage, wastewater management, heating, cooling and ballast tank control.



Technical Data

Type	GS4200H	GS4201H	GS4202H/GS4212H	GS4203/GS4213H
Sensor Technology:	Silicon-on-Sapphire (SOS)			
Output Signal:	4-20 mA (2 wire)	0-10 mV/V (4 wire)	0-5 V (4 or 3 wire)	0-10 V (4 or 3 wire)
Supply Voltage:	10-36 VDC	10 VDC (5-15 V)	13-30 VDC	13-30 VDC
Pressure Reference:	Gauge			
Protection of Supply Voltage:	Protected against supply voltage reversal up to 50 V (amplified versions)			
Standard Pressure Ranges (bar):	0 – 1 bar Vac; 0 – 0.5 bar; 0 – 1 bar; 0-2.5 bar; 0-6 bar; 0 – 10 bar; 0-16 bar; 0 – 25 bar; 0 – 100 bar; 0 – 250 bar; 0-400 bar; 0 –600 bar; 0-1,000 bar; 0 – 1,500 bar (other ranges available)			
Standard Pressure Ranges (psi):	0-30 in Hg; 0-7.5 psi; 0-15 psi; 0-30 psi; 0-100 psi; 0-150 psi; 0-200 psi; 0-300 psi; 0-1,500 psi; 0-3,000 psi; 0-6,000 psi; 0-8,700 psi; 0-15,000 psi; 0-20,000 psi (other ranges available)			
Overpressure Safety:	4x for 0.5 bar range; 2x for ranges -1 bar to 600 bar; 1.5x for 1,000 bar range; 1.1x for 1,500 bar range			
Load Driving Capacity:	4 – 20 mA: RL < [UB - 10 V] / 20 mA (e.g. with supply voltage (UB) of 36 V, max. load (RL) is 1300 Ω) 10 mV/V: n/a; 0 – 5 V: max. load RL > 5 KΩ; 0 – 10 V: max. load RL > 10 KΩ			
Accuracy NLHR:	≤ ±0.25 % of span BFSL (Optional higher accuracy version of ≤ ±0.1 % of span BFSL available)			
Zero Offset and Span Tolerance:	±0.5 %FS at room temperature (GS4201: ±1 mV); ±5 %FS (approx.) adjustment with easy access trimming potentiometers on amplified versions only			
Operating Temperatures:	Ambient: 40 °C to +85 °C (-40 °F to +185 °F) Media: -50 °C to +125 °C (-58 °F to +257 °F)			
Storage Temperature:	+5 °C to +40 °C (+41 °F to +104°F) Recommended Best Practice			
Temperature Effects:	±1.5 %FS total error band for -20 °C to +70 °C. Typical thermal zero and span coefficients ±0.015 %FS /°C			
ATEX/IECEX Approval Option (4-20 mA version only):	Ex II 1 G Ex ia IIC T4 Ga (zone 0) Ex II 1 D Ex ia IIIC T135 °C Da (zone 20) Ex I M 1 Ex ia I Ma (group 1 M1)	n/a	n/a	n/a
ATEX/IECEX Safety Values:	Ui = 28 V Ii = 119 mA Pi = 0.65 W Li = 0.1 μH Ci = 74 nF Temperature Range = -20 °C to +70 °C Max. cable length = 45 m	n/a	n/a	n/a
DNV-GL Approval:	Temperature: D; Humidity: B; Vibration: B; EMC: B; Enclosure: C (contact sales for more information)			
Electromagnetic Compatibility:	Emissions: EN61000-6-3; Immunity: EN61000-6-2; Certification: CE Marked			
Insulation Resistance:	> 100 MΩ @ 50 VDC			
Response Time 10-90%:	1 mS			
Wetted Parts:	Titanium alloy (1/4" BSP male (G1/4) and 1/4" NPT male thread); ; other threads typically Titanium alloy/316L stainless steel			
Pressure Media:	All fluids compatible with Titanium alloy (1/4" BSP male (G1/4) and 1/4" NPT male); other threads typically Titanium alloy/316L stainless steel			
Pressure Connection:	1/4" BSP male (G1/4); 1/4" NPT male; 1/2" BSP male (G1/2); 1/2" NPT male and 1/4" BSP female (others options available)			
Electrical Connection:	Mating socket EN175301-803 Form A (ex DIN43650) rated IP65 with PG9 cable entry (other options available)			
Net Weight:	0.2 Kg			

Order Matrix

Output	Wires	Type	Options	Pressure Range	Process Connection			
4-20 mA	2	GS4200						
10 mV/V	4	GS4201						
0-5 V	4	GS4202						
	3	GS4212						
0-10 V	4	GS4203						
	3	GS4213						
Options								
DIN EN175301 plug and socket						H		
Cable outlet 1m screened			HA					
M12 connector			HB					
Cable outlet 1m screened IP67 protection			HC					
ATEX/IECEX certified with DIN EN175301 plus and socket			EXH					
DNV GL approval			MH					
DNV GL approval plus ATEX/IECEX certified			EXG					
Pressure Range in bar								
0-1 bar Vac				V001				
0-0.5 bar				00.5				
0-1 bar				0001				
0-2.5 bar				02.5				
0-6 bar				0006				
0-10 bar				0010				
0-16 bar				0016				
0-25 bar				0025				
0-100 bar				0100				
0-250 bar				0250				
0-400 bar				0400				
0-600 bar				0600				
0-1000 bar				1000				
0-1500 bar				1500				
Process Connection								
1/4" BSP male (G1/4)					AB			
1/4" NPT male					AM			

Order Number Example GS4200H0600AB

For options not listed please contact the sales team

DISCLAIMER : ESI Technology Ltd operates a policy of continuous product development. We reserve the right to change specification without prior notice. All products manufactured by ESI Technology Ltd are calibrated using precision calibration equipment, traceable to national measurement standards.